

Getting Started

Welcome to Analytix, the sketch-based mechanism design and analysis package.

This chapter will help you get Analytix up and running by discussing:

- What hardware you need
- How to use the Analytix manuals.

What You Need

System Requirements include:

- IBM PC - AT 286, 386, 486 or compatible, or any computer capable of running MS Windows
- DOS 3.1 or above
- 640K RAM
- Hard Disk
- Mouse or other Windows compatible pointing device
- MS Windows 3.0 or above.

About This Manual

By working through the detailed example in this manual, you will acquire a sufficient understanding of the program to experiment on your own.

Feature Summary

In this chapter we will outline the features and functions which make Analytix a powerful design and analysis tool.

What is ANALYTIX?

Analytix is a software tool that helps you create, analyze, and solve design problems of virtually any mechanism, especially those with moving parts. Through the easy-to-use Constructive Variational Geometry engine and Windows user interface, you can use Analytix like pencil and paper to sketch the geometry of your design. You can then annotate, dimension, and constrain the geometry.

The power of Analytix is in the system's ability to construct geometry from dimensional information. In a traditional CAD package, the user must furnish the geometry which is used to extract dimensional information. Alternatively, Analytix allows you the flexibility to formulate solutions to design problems. Analytix is not a drawing package where the design is already understood, but rather a conceptual tool where the user is free to play with design parameters until the correct geometric solution is achieved.

Besides providing an easy-to-use and powerful sketching and dimensioning tool, Analytix is also equipped with powerful and versatile analytical capabilities. Once the geometry is sketched and consistently dimensioned, you can use Analytix to analyze the design's static, kinematic, dynamic, and tolerance characteristics. To use Analytix's analytical

capabilities, you may need to specify initial conditions and model constraints such as velocities, accelerations, tolerances, masses, applied forces, springs, dampers, and actuators. Based on the information you specified, Analytix will perform a full range of force analyses which include static, inverse-dynamic, kinematic, and tolerance analysis. Analytix is also able to display the analysis results in easy-to-understand tables and graphs. In addition, Analytix supports exporting data to other Windows applications such as a spreadsheet program for further analysis and optimization.

Functionality

Analytix's capabilities can be organized into the following function groups:

- Drawing functions
- Analysis functions
- Animation functions
- Calculator and Equation functions
- Support functions

Drawing Functions

Analytix's drawing functions enable you to create a drawing that models the mechanism you wish to design. These functions include:

Sketching Functions - These functions let you sketch graphical entities: points, lines, fillets, arcs, circles, and construction lines to create the geometry for your design.

Note that the drawing model Analytix uses is different from other Computer Aided Design (CAD) applications. Analytix allows you to sketch geometry freehand without concern about dimensions. This flexibility gives you the ability to quickly come up with a rough geometry without being bogged down in dimensional details. When you have sketched the geometry, you can then dimension it. When the geometry is consistently dimensioned, Analytix will automatically redraw the geometry to scale. See the last chapter in this manual, "Inconsistencies and Redundancies", for a more detailed discussion on dimensioning.

Annotation Functions - Annotation adds alphanumeric to the drawing. A previously defined

variable can be used in an expression which Analytix automatically updates whenever there is a change.

Dimension Functions - These functions let you specify dimensions to the geometry or ask Analytix to automatically dimension it for you. The dimension functions enable you to specify: length of a line, distance between a pair of parallel lines, perpendicular distance between a line and a point, distance between a pair of points, angle between two lines, tangency between a circle or arc and a circle or arc or line, and the position of a point on a line or circle. Furthermore, Analytix can automatically dimension your geometry. See your *Analytix Reference Manual*, "Dimension" chapter, for more detail on the Automatic feature.

Edit Functions - Through the Edit functions, you may select single, multiple, entities of a type, or all entities in the drawing. After you have selected the entities, you can change their values, or cut or copy them to the clipboard. You can also paste the contents of the clipboard into your drawing.

Constrain Functions - The Constrain functions let you specify that two or more line segments are to be on the same line and two or more points and / or centers of circles are to be identical. Through these functions, you can also fix a point and / or a line and set a line to be either vertical or horizontal.

View Functions - These View functions let you move or rotate the drawing, zoom in on the drawing, blank a selection of entities in the drawing (e.g., all dimensions or all annotations), and unblank entities. To allow finer control over what is visible, the View functions allow you to put entities of your drawing into one of the 16 levels and apply Blank and Unblank functions to the selected level(s).

Analysis Functions

The analysis functions let you perform statics, kinematics, dynamics, and tolerance analysis on your design. You can not only dimension and constrain your design geometry, but also add specifications to points and lines in the geometry.

For each point in the geometry you can specify:

- Position
- Velocity
- Acceleration
- Mass
- Applied force

For each line in the geometry, you can also specify:

- Angular velocity
- Angular acceleration
- Tolerance
- Inertia
- Applied torque
- Bar properties (for trusses)

For an actuator in the drawing you can specify:

- Spring properties
- Damping coefficient
- Black Box formula for a force

With the above specifications added to the dimensioned and constrained geometry, Analytix will derive and display these values for points or lines:

- Velocity
- Acceleration
- Position
- Shear and Bending Moment
- Stress and Deflection (for trusses)

Analytix will compute the following values for dimensions:

- Force
- Torque
- Tolerance

Analytix can also display the above information for a range of values in tables and graphs.

Animation Functions

In addition to the calculation oriented analysis, Analytix also provides animation and increment functions to let you determine if a mechanism's movement will satisfy the design requirements. To use these functions, you need to select the driving entity (such as an angle), specify its initial and final values, and determine the increment. You can then initiate the display of:

- Animated movement
- Trace of a point
- Envelope of motion

Calculator and Equation Functions

Analytix provides two calculation tools that help you evaluate expressions and solve equations. The expression calculator lets you define variables and evaluate expressions consisting of numbers, variables, and functions. There are two equation solvers: one solves for a single variable, the other solves simultaneous multivariable equations. Both of these equation solvers let you enter equations consisting of numbers, variables and functions. Analytix implements uni- and multivariate root finders to support these equation solvers. While the equation solvers are useful for solving equations alone, their real power comes when they are coupled with the drawing and drawing functions. See the description of the Tools / Uni/Multivariate Iteration menu items in the reference manual for an example

with the drawing and drawing functions. See the description of the Tools / Uni/Multivariate Iteration menu items in the reference manual for an example of how the equation solvers can be used to settle design issues.

Support Functions

The support functions allow you to set various defaults and drawing options, and display drawing attributes and measurements:

- Choose default pen color, style and width and font
- Enlarge or shrink the pick aperture
- Display dimensions either as expressions or values
- Select unit system and drawing alignment
- Specify default linear and angular tolerances that will be applied to the geometry
- Calculate tolerances as either statistical or absolute
- Set default bar properties for cross sectional area and modulus of elasticity
- List an entity's attributes
- Report various measurements from the drawing, e.g. distances, angles, areas, area moments.

Example: A Film Drive

With the above overview of what Analytix can do, we will use an example to illustrate how you can use some of these capabilities to solve a mechanical design problem.

The mechanism that we'll analyze is an intermittent film drive in a movie projector as depicted in the figure below.

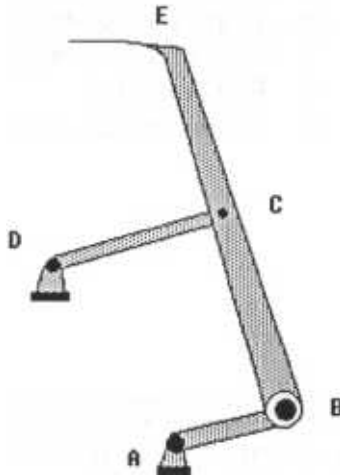

Crank AB drives the motion. The hook at E is required to advance the film downward, with engagement and disengagement close to right angles to the film. The linkages have tolerance of 0.01 on their lengths and 0.1 on their angles. We will design such a mechanism and verify that the mechanism indeed produces a downward motion that satisfies the engagement and disengagement requirements.

We will also examine the tolerance on the vertical location of the hook at the start of the downward stroke. In addition, we will study the kinematic, dynamic, and static characteristics of the mechanism. Through the process of designing the mechanism and examining its physical characteristics, we will discuss the following topics in the ensuing subsections:

- Invoke Analytix
- Create the Drawing
- Animation and Geometry Analysis
- Kinematic Analysis
- Dynamic Analysis
- Tolerance Analysis
- Applying Loads
- Save and Document the Work
- Exit Analytix
- Inconsistencies and Redundancies

Building the Model

Invoke Analytix

After Analytix is properly installed in the Windows environment, you can invoke it by positioning the mouse pointer on the Analytix icon and double click the left mouse button. You will see the Analytix window appears on the screen with an empty workspace.

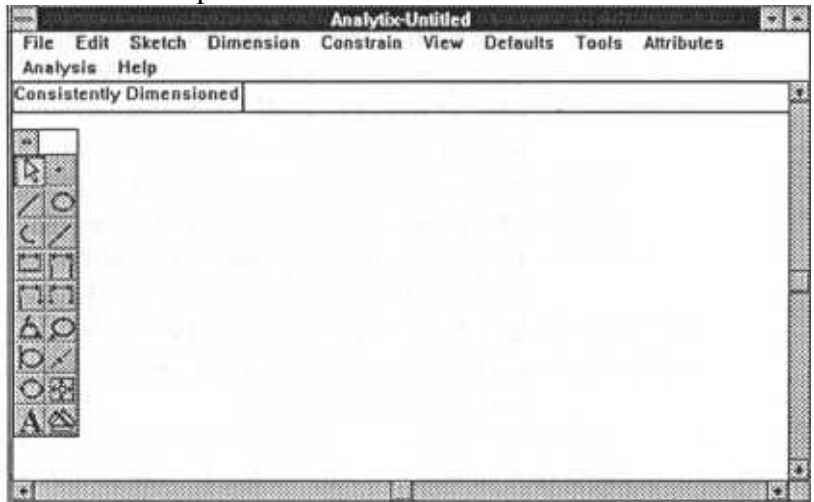

The title bar has the caption "Analytix - Untitled" indicating that this is a new Analytix window and the work has not been saved.

Below the title bar is the menu bar that lists all the menu items you can select.

Below the menu bar are two rectangular boxes.

The box on the left is the Drawing Status Box that tells you the dimension status of the geometry.

When there is a drawing on the screen, one of the



















following messages may appear in this box to inform you of the current dimension status of the geometry.

- Under Dimensioned
- Consistently Dimensioned
- Inconsistent dimension
- Redundant Dimension

These messages are discussed at the end of this manual - (see "Inconsistencies and Redundancies"), and more fully in your Analytix reference manual, the "Dimension" chapter.

The box on the right is the message area that displays information or messages. Most frequently, it identifies the entity under consideration. For example, if you select a point, you will see a message like "POINT17 (4.607500,6.750000)" in the box identifying the point by its name and position.

Below the message area is the Analytix workspace. The palette of icons on the left represent some frequently used operations. Each of these operations can also be invoked through the pull-down menus listed in the menu bar. These icons, their functions , and corresponding menu items are listed in the table on the following page.

<u>Icon</u>	<u>Function Performed</u>	<u>Corresponding Menu / Item</u>
	Select an entity in drawing	Edit / Select
	Sketch a point	Sketch / Point
	Sketch a line	Sketch / Line
	Sketch a circle	Sketch / Circle
	Sketch an arc	Sketch / Arc
	Sketch a construction line	Sketch / Construction Line
	Specify length of a line	Dimension / Line Length
	Specify distance between two parallel lines	Dimension / Parallel Distance
	Specify perpendicular distance between a line and a point	Dimension / Line to Point
	Specify distance between two points	Dimension / Point to Point
	Specify angle between two lines	Dimension / Angle
	Specify radius of a circle	Dimension / Radius
	Specify circle or arc as tangent to a line, a circle, or an arc	Dimension / Tangent
	Specify that a point lies on a line	Dimension / Point on Line
	Specify that a point lies on a circle	Dimension / Point on Circle
	Zoom in on your drawing	View / Zoom Box
	Add annotation to drawing	Sketch / Annotation
	Let Analytix automatically dimension the geometry	Dimension / Automatic

Create the Drawing

We are now ready to create the drawing for the mechanism previously specified. Here are the steps:

- 1 - Select a wider line width for geometry
- 2 - Sketch the geometry
- 3 - Dimension the geometry

4 - Constrain the geometry

5 - Annotate the geometry

Select Wider Line Width for Geometry

Because the default geometry and dimension lines have the same line width, it is sometimes difficult to distinguish one from another on black and white monitors and print outs. We can correct this problem by choosing a wider width for sketching geometry. The steps to accomplish this are:

Select the Defaults / Default Pens menu item to display the dialog box below

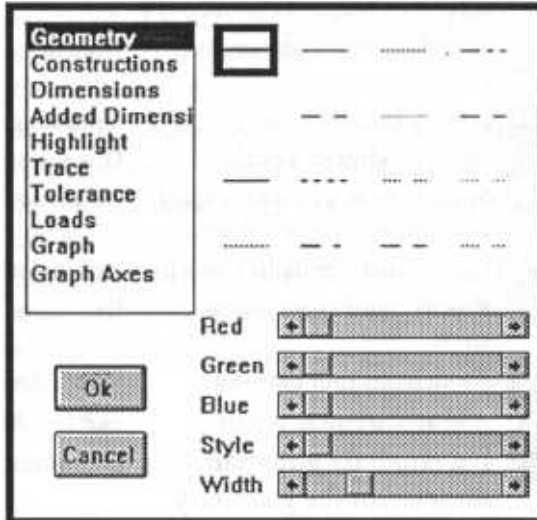

Ensure that Geometry is highlighted and the black rectangle displaying the default line color selection encircles the black line next to Geometry.

Click on the right arrow of the scroll bar next to Width until the black thin line in the rectangle becomes about twice its original thickness.

Sketching the Geometry

We will first make a complete sketch without dimensions. Start by either selecting the Sketch Line icon on the tool palette or the Sketch/Line menu item to enter line drawing mode. Then draw a line representing linkage AB with *the* following steps:



For point A, position the mouse anywhere in the lower right area of the window and click the left mouse button

The mouse pointer changes from an arrow to a cross with a square at the center.

Move the crosshair up and right to a location for point B, and click the left mouse button again

The line for linkage AB is now drawn. The Dimension Status Box displays Under Dimensioned indicating that the drawing has not been fully dimensioned yet. The message box shows the name and position of the end point.

When you start each successive line, be sure that the crosshair is on top of the end point of the adjacent line. The message box will display POINTx (xcoord, ycoord). This is a shortcut way to automatically constrain adjacent lines end points to the same point. Or, two lines can also be explicitly joined by selecting the respective end points, then using the menu item Constrain/Same Point

Tip: to select more than one entity at a time, hold down the [Shift] key while clicking on the entities.

We now use the same procedure to complete the geometry. Refer to the sketch on page 21: Draw lines BE, AF, and FD. Draw line DC last - as you finish drawing line DC, be sure that line BE turns red (indicating that it is selected for joining point-to-line). This is the way to automatically constrain a line's end point to an intersection with a line.

We now use the same procedure to complete the geometry.

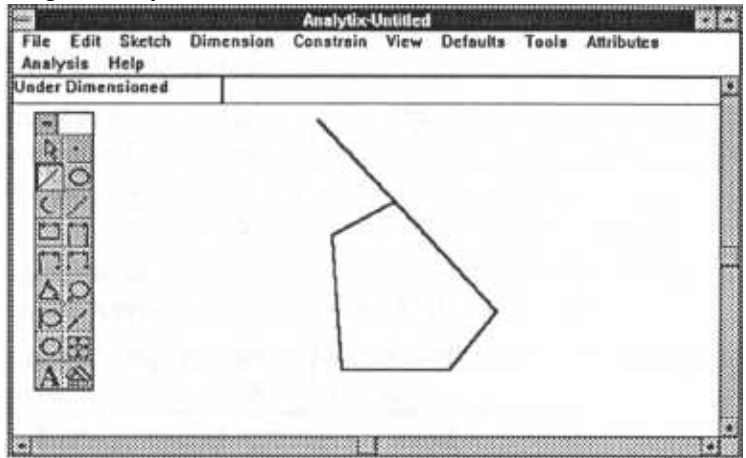

During the sketching process, if we made an error and wish to delete an entity, say a line, we need to first select the entity. To change from Sketch to Select mode simply click on the right mouse button or click the mouse pointer over the Select icon (the arrow). Next, move the mouse pointer above the entity to be selected and click the left mouse button. The entity will turn red indicating that it is selected. Then, press the Delete key on the keyboard or select the Edit / Cut menu item to delete the line.



Annotation

To make dimensioning and analysis easier, we would like to label the points using the annotation function. The following steps demonstrate how to annotate point A with character "A":

- *In select mode, click on point A to indicate that the annotation will be relative to this point*
- *Click on the Annotation icon*
- *Move the mouse pointer to a location where you want to place character "A"*



- Click the left mouse button to display the following dialog box
- Type "A" in the input area (just below the header bar) where the typing cursor is blinking
- Leave the Tag Line and Border boxes empty
- Click on the Ok button

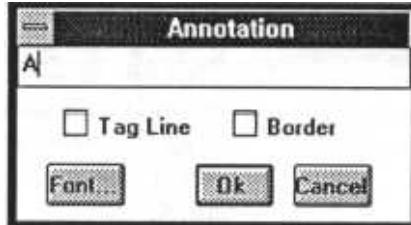

A red character "A" appears in the desired location. Repeat the procedure and label points A through F as shown below.

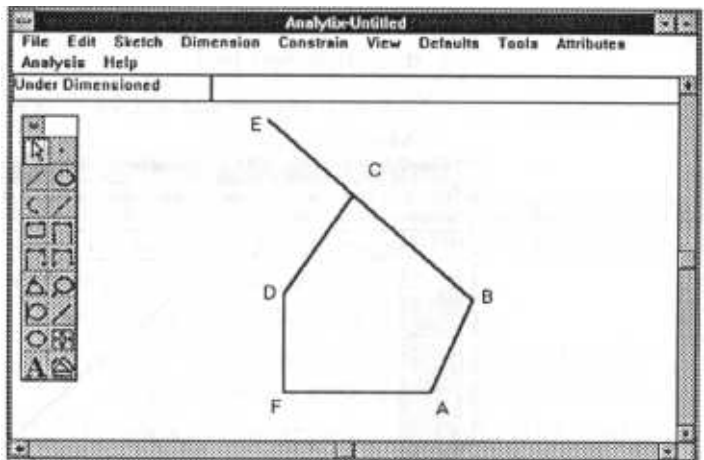

Dimensioning the Geometry

You may use any internally consistent set of units for dimensioning geometry. Units need to be specified only when you use Analytix's Statics and Dynamics functions (discussed later in this tutorial). Check the Defaults/ System Defaults menu to ensure that the angles are specified in degrees.

The dimensions specified for our drawing are the following: $AB = 2$, $BE = 12$, $BC = 5$, $DC = 3$, $AF = 4$, $DF = 4$, Angle $DFA = 90^\circ$.

We will follow the procedure below to specify the length for line AB:



- *Select the Dimension Line icon*
- *Move mouse pointer over line AB*
- *Press and hold the left mouse button; a dimension line appears attached to the pointer*
- *Drag the cursor so that the dimension line is placed appropriately and release the left mouse button*
- *Type the dimension value "2" in the Dimension Entry Box.*
- *Click on the Y button or press the Enter key*

The dimension dialog box disappears and line AB is dimensioned to 2.

We will repeat the above procedure for lines BE, DC, AF, and DF.

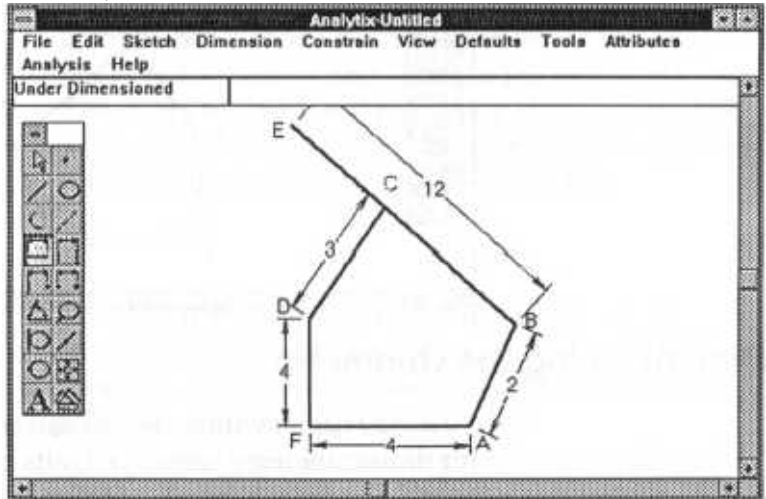

There is one remaining linear dimension, BC, which is a point to point dimension. The steps are similar to the dimensioning of line lengths detailed above:



- *Select the Dimension Point to Point icon*
- *Click the mouse with the cursor over point C*
- *With the cursor over point B, press and hold the mouse button and drag the dimension line to an appropriate position*

Proceed as with the line length to enter the dimension.

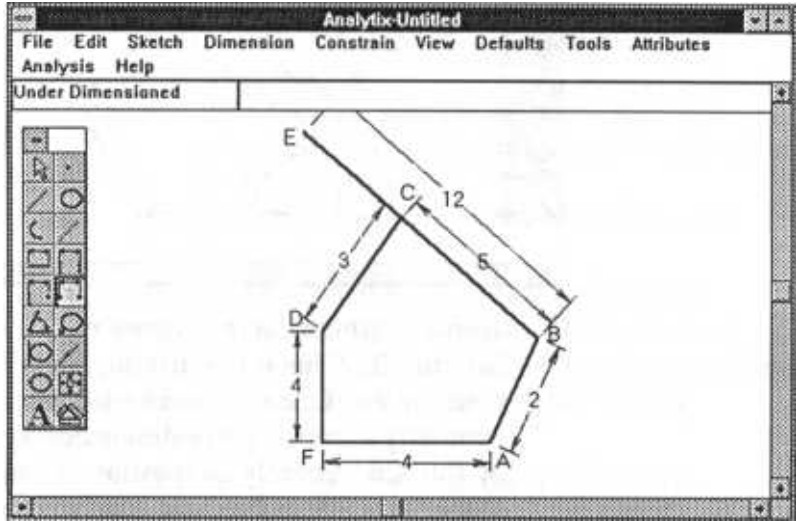

Next we will dimension angle DFA. The steps to dimension an angle are as follows:



- *Select the Dimension Angle icon*
- *Click the mouse with the cursor over line DF*
- *Click the mouse with the cursor over line FA*

The dimension line appears on angle DFA and a dialog box appears in the Dimension Status Box waiting for you to input the value for the angle

Type in "90"

Click on Y or press the Enter key

Angle DFA is now dimensioned to 90.

Notice that the Dimension Status Box displays "Under Dimensioned", telling us that we are still

missing some dimension(s).

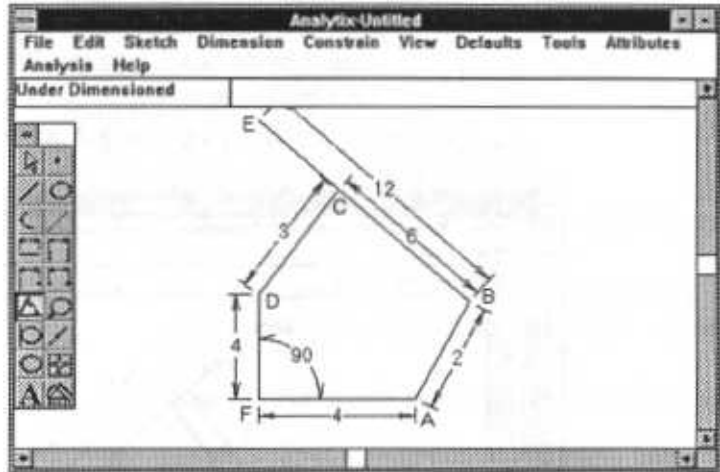

To fully dimension the geometry, we will set angle BAF to 120. This is the driving angle for the mechanism. Once angle BAF has been specified, the geometry is consistently dimensioned as evidenced by the "Consistently Dimensioned" message in the Dimension Status Box and Analytix draws the geometry to scale automatically.

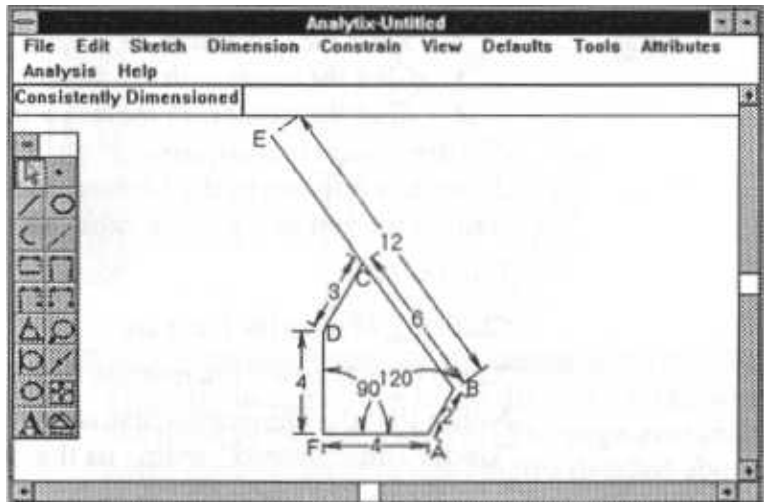

Constrain the Geometry

Because point A and point D are grounded parts of the mechanism, we need to do the same for our model. Analytix can fix a point and a line at the same time, so we will fix point A and line FA to ground. The procedure is as follows:



- *Click the Select icon to enter select mode*
- *Select line FA*
- *Hold down the shift key and while holding it down Select point A (holding the shift key enables multiple selections)*
- *Select the Constrain / Fix Point/Line menu item*

A pin icon appears at point A and a roller icon appears in the middle of line FA. The two icons signify that point A cannot move (i.e. it is pinned to the ground) and line FA cannot rotate during animation.

Point D is fixed as a result of the dimensions defining its positions: line lengths DF and FA, and angle DFA.

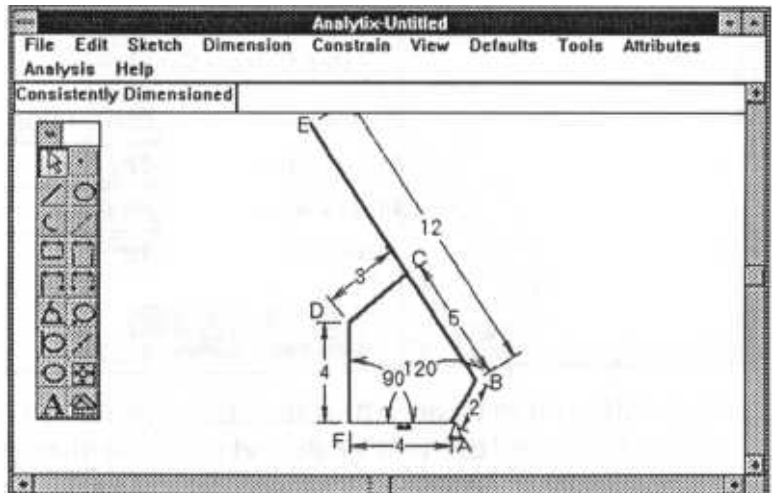

Animation and Geometry Analysis

At this point, we are ready to begin analyzing the geometry of the design.

Animating the Geometry

Using the animation feature we can see the motion of the linkages within the mechanism. Animation is done as follows:

Select the Tools /Animate menu item

A dialog box appears where we enter information in the following fields:

- Iterator: specify the iterator by clicking on the dimension of angle FAB
- Initial Value: enter 120
- Final Value: enter 480
- Increment: enter 10

Click on the Ok button

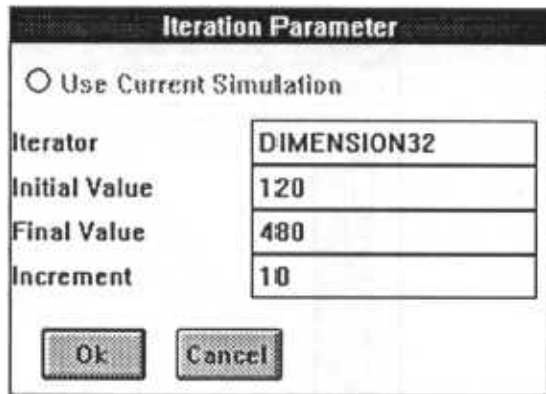

Iteration Parameter	
<input type="radio"/> Use Current Simulation	
Iterator	DIMENSION32
Initial Value	120
Final Value	480
Increment	10
<input type="button" value="Ok"/> <input type="button" value="Cancel"/>	

Crank AB rotates clockwise for 360 degrees and drives lines BE and CD along their paths of motion. Angle FAB shows the final value of 480 degrees.

Tracing a Point

We will use the trace function to verify that point E travels a near straight line down stroke and engages and disengages at an angle close to 90 degrees. To produce the trace for point E's motion we perform the following:

Select point E

Point E's name and position appear in the message box confirming the point is selected.

Select the Tools / Trace menu item

An Iteration Parameter dialog box (same dialog box as in the animation function) appears with the same parameter values we previously specified for animation. No need to change any of the parameters.

Click on Ok

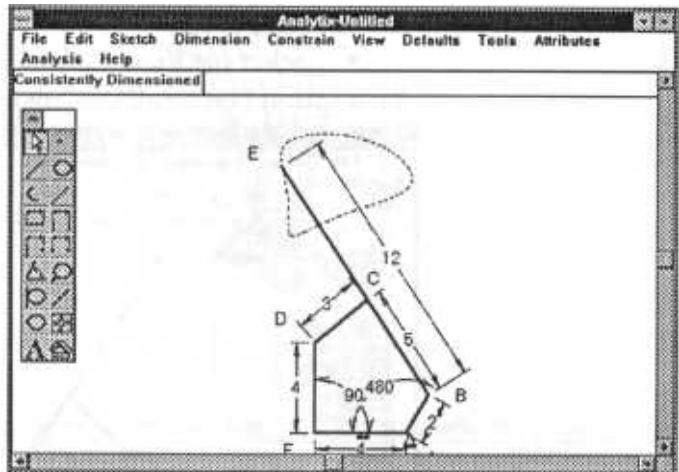

The trace of point E's motion appears with a cuspid like shape. The trace confirms that point E moves downward in a straight line and its engagement and

disengagement movements do occur at close to right angles.

To erase the trace simply select Edit 1 Erase Background.

Blanking Dimensions and Annotations

During the animation, the dimension lines move along with the geometry. On some occasions the line and angle dimensions as well as annotation text overlap one another and the drawing becomes very crowded. To avoid dimensions and annotations obscuring the geometry during animation, we can make them temporarily invisible, or blank them out. To do this:

- *Select the Edit / Select All... Dimensions menu item which changes all dimension lines from blue to red*
- *Select the Edit / Select All... Annotations menu item which changes all annotations from black to red*
- *Select the View / Blank menu item*

This action blanks all dimensions and annotations.

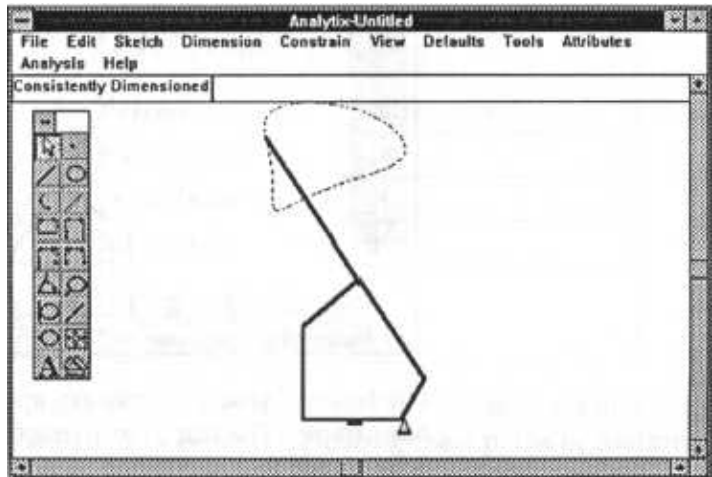

Display the Range of Motion

To view the envelope of the geometry's motion, perform the following:

Select the Tools / Envelope menu item.

An Iterator Parameter dialog box (same dialog box as in the animation function) appears with the same parameter values we previously specified for animation and trace.

Click on Ok.

Analytix displays the envelope of the geometry's motion as line AB cranks over the full revolution. Notice that line BE's envelope follows the trace of point E.

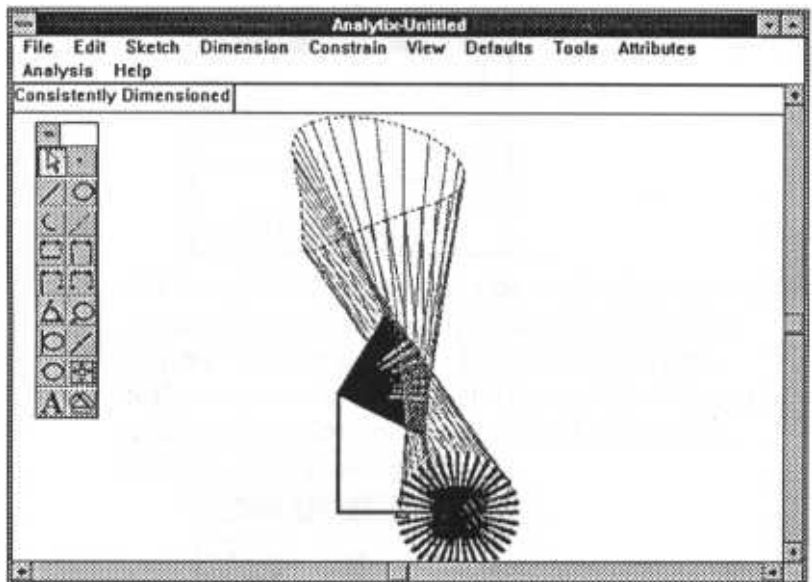

To erase the envelope, we simply select Edit / Erase Background and the original geometry reappears.

Unblank the Dimensions and Annotations

After animation, we wish to see the dimensions and annotations again. To make the previously blanked entities reappear, we simply select View / Unblank All to redisplay the dimensions and annotation.

Kinematic Analysis

We are interested in determining the velocity at point E if line AB rotates at an angular velocity of 1 radian per second. Note that the Defaults / System Defaults dialog box specifies the selection of angular units for kinematics. To construct the kinematic model, we first specify the angular velocity of angle FAB as follows:

- *Double click angle FAB's dimension to display the information dialog box for the angle*
- *Enter 120 to the Value field*
- *Enter 1 to the Velocity field*
- *Leave the remaining fields unchanged*
- *Click on Ok*

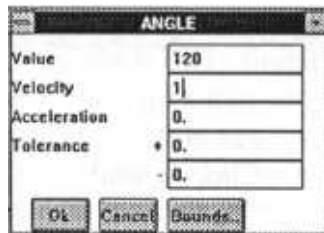

With angle FAB having the desired velocity, we can examine point E's velocity and acceleration by double clicking point E. This will display the following dialog box which shows the horizontal and vertical components of point E's position, velocity, and acceleration.

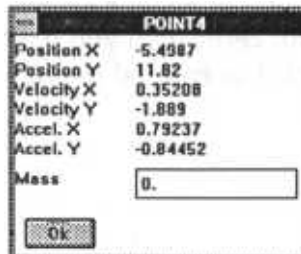

Graphing and Tabulating Results

The above analysis reveals the kinematic conditions of point E when angle FAB is at 120 degrees and line AB is rotating at one radian per second. Given the same angular velocity of line AB, what will be the kinematic conditions of point E throughout an entire revolution of the crank? Analytix is able to answer this kind of question with graphs and tables. If we would like to graph the velocity magnitude of point E versus the driving angle, we will do the following:

- *Select Tools / Graph menu item to display the Graph Parameters dialog box*
- *Fill in the Parameter t box by clicking on angle FAB's dimension*

This causes "DIMENSION32" to be entered in the box (Note: the dimension name you see may be different. This is not important. Analytix provides a unique name for each entity).

- *Fill in the Y axis variable field by typing "vel(".*
- *Click on point E which inserts "POINTxx" after "(" , the open parenthesis, where xx is the point number assigned by Analytix.*
- *Type in the closing parenthesis,*

The Initial t, Final t, and t increment fields will already be defined from our previous operations.

- *Click on Ok*

A graph showing point E's velocity magnitude as a function of angle FAB is displayed. (Note: If you get all zeros then you may not have closed the bracket or entered the function name properly.)

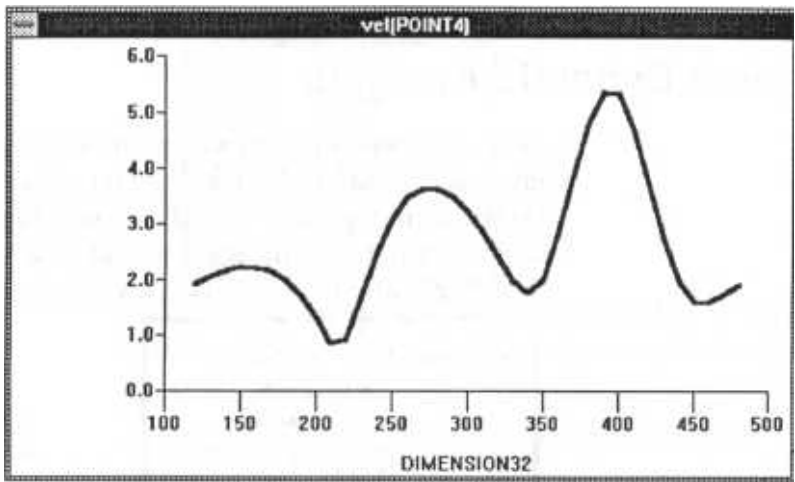

Use the Graph window's System icon box to instantly convert the graph to a table or to plot the graph on your printer.

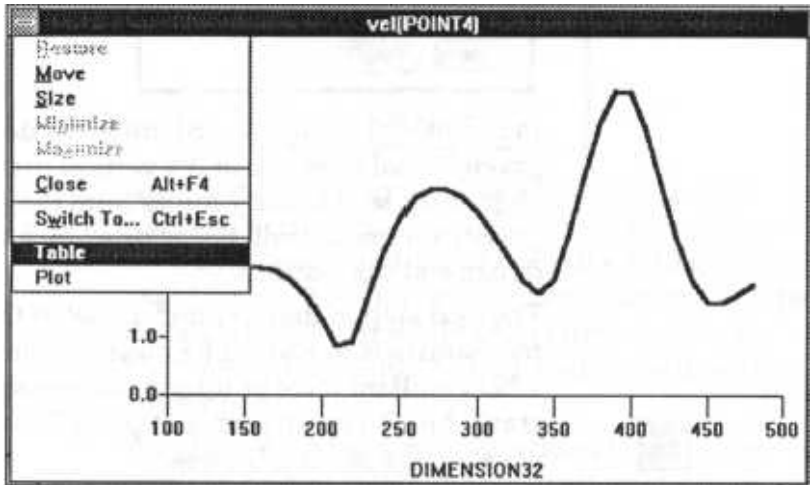

Inverse Dynamic Analysis

Before proceeding with a dynamics analysis it is important to take a look at the Defaults / Dynamics Defaults dialog box. This allows you to specify units, a gravitational constant, and how your drawing is aligned with the gravitational force.

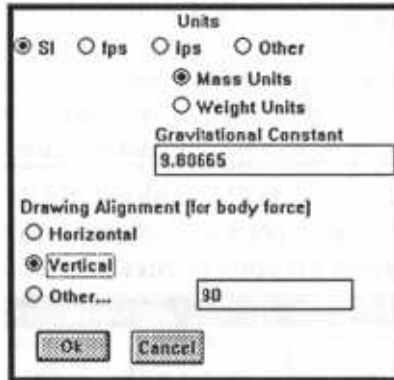

In our model we will use SI units, the default gravitational constant, and a vertical drawing alignment, so that body forces from the effect of gravity on masses will be included in Analytix's dynamical calculations.

The next step in the dynamic model of the mechanism is to add a 2 kg mass at point E and see what resultant force or torque this mass produces on crank AB. To specify mass at point E:



- *Click on the select icon*
- *Double click on point E to open its dialog box*
- *Enter 2 in the Mass field*

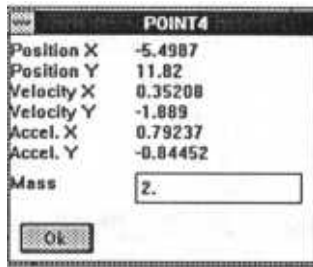

Point E, having mass, velocity, and acceleration, is creating a torque on crank AB. To study the torque on crank AB:



Select angle FAB by clicking on the angle dimension

Select Analysis / Resultant Force/Torque

Analytix displays the resultant torque in a pop-up window.

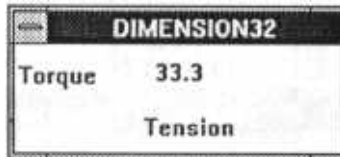

Note that the popup window specifies that the torque is in compression; i.e., the resultant torque from a mass on point E and line AB rotating at an angular velocity is forcing the angle closed. At other values for FAB you might see a torque in tension. That means the torque on that angle is pulling the angle open.

We can use the increment function to change the crank angle and watch the resultant torque instantly update in the window:



Make sure angle FAB is selected (its dimension should be red).

Select Tools / Increment to display the Increment dialog box.

Notice that the Iterator field has specified DIMENSION32 indicating angle FAB and the Value field should have the current angle at 120. The remaining values should also be specified from previous operations: Initial Value = 120, Step Size 10, Final Value = 480, and Large Step Size = 40.

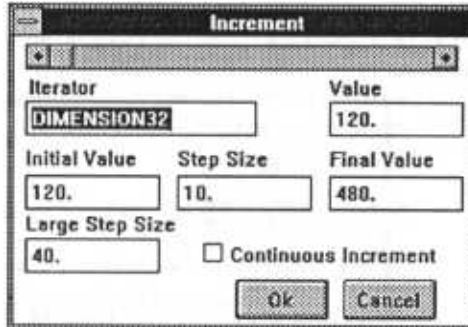

We can then click on the right arrow of the scroll bar at the top of the Increment dialog box to increment the angle by the step value, 10, to 130 degrees.

Notice that the torque value in the torque window changes as a result. We can tabulate the torque at different angles or draw a graph of torque against angle using the Tools / Table and Tools / Graph functions that we have used during the kinematic analysis. The only change to make is in the Y axis variable field when we open the table or graph dialog box. The correct function is "react(DIMENSION32)". Analytix will generate the graph or table for torque.

Table		
Copy	Graph	Print
DIMENSION32	act	DIMENSION3
120.	-33.3	
130.	-36.667	
140.	-39.918	
150.	-42.606	
160.	-44.406	
170.	-45.019	
180.	-44.027	
190.	-40.602	
200.	-32.99	
210.	-18.406	
220.	4.081	
230.	27.681	
240.	41.576	
250.	43.308	
260.	37.804	
270.	29.761	
280.	21.663	
290.	14.757	
300.	9.9137	
310.	8.0383	
320.	10.224	

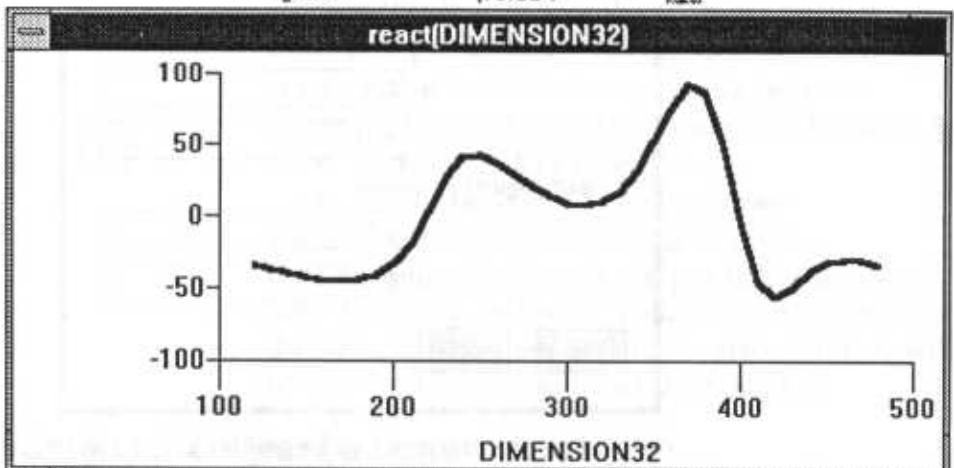

As you can see from the top of the table window, it is also very easy to instantly convert your table into a graph, or copy it to the Clipboard, or obtain a plot.

Tolerance Analysis

Because all physical linkages have tolerances, our model must take tolerance into consideration to be realistic. We can specify linear and angular tolerances for all entities in the geometry and analyze the result of this tolerance specification.

We will specify default linear tolerance of 0.01 and angular tolerance of 0.1 for all entities in the geometry:

- *Select Defaults / Default Tolerance... to display the tolerance dialog box*
- *Enter 0.01 to the \pm (plus) and \mp (minus) fields for Default Linear Tolerance*
- *Enter 0.1 to the \pm and \mp fields for Default Angular Tolerance*
- *Click on Ok*

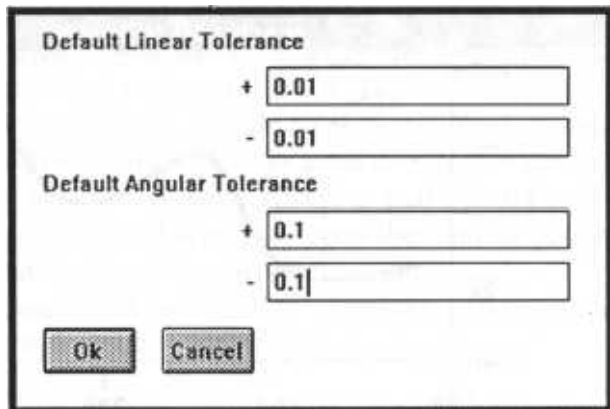

The image shows a dialog box titled "Default Tolerance". It is divided into two sections: "Default Linear Tolerance" and "Default Angular Tolerance". Each section has two input fields: one for the positive tolerance (marked with a plus sign) and one for the negative tolerance (marked with a minus sign). In the "Default Linear Tolerance" section, both fields contain the value "0.01". In the "Default Angular Tolerance" section, both fields contain the value "0.1". At the bottom of the dialog box, there are two buttons: "Ok" and "Cancel".

Individual tolerances can be adjusted for any dimension from the Attributes / Info menu after first selecting that dimension, or simply by double clicking on the dimension.

Tolerance Zone

With the above tolerances applied to the linear linkages and angles, we would like to examine what effect they have on the position and motion of point E. Analytix can display point E's tolerance zone, an area in which point E is guaranteed to lie, as well as the tolerance trace which shows point E's possible positions during its motion. The tolerance analysis results that Analytix returns can either be absolute or statistical depending on the tolerance mode you select. The tolerance mode is selected via the Defaults / Max Min Tolerance and Defaults / Statistical Tolerance menu items. In absolute tolerance mode, all tolerance input and analysis results are specified in absolute bounds. In statistical tolerance mode, all tolerance input and analysis results are specified in statistical terms based on a Normal Distribution. See the reference manual for detailed explanation of each mode.

We will use absolute tolerance analysis in our example. To generate the tolerance zone for point E:



- *Select point E by clicking it*
- *Select Analysis/ Tolerance Zone*

The mouse pointer turns into an hourglass indicating that Analytix is computing the tolerance zone at point E. When the computation is complete, the hourglass changes back to the arrow and we will note a small black dot-like area on point E.

Zoom in on Tolerance Zone

At its normal size, the tolerance zone is too small to study. Analytix provides zooming functions that allow us to zoom in (enlarge) on any portion of the drawing or zoom out (shrink) on the enlarged

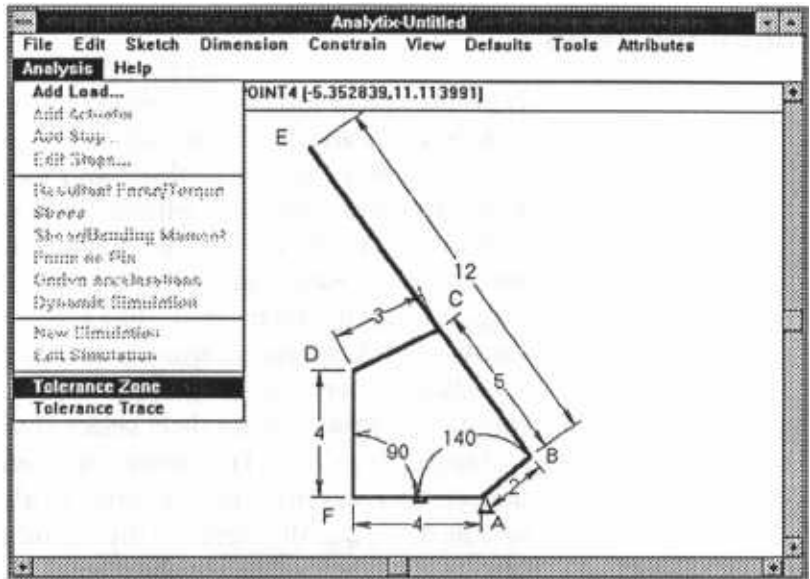

drawing. We will now enlarge the tolerance zone at point E using the Zoom Box function Analytix provides:



- *Select the Zoom Box icon from the tool box or the View / Zoom Box menu item.*
- *Position the mouse pointer to the upper left corner of the area on which you want to zoom in.*
- *Press and hold the left mouse button.*

A rectangle appears with the lower right corner attached to the cursor.

- *Holding the mouse button, drag the rectangle so that it encloses the area to be enlarged.*
- *Release the left mouse button.*

The tolerance zone is enlarged to afford a clear view. Further enlargement can be done by repeating the above procedure.

To return the drawing back to its original size, select View / Zoom Min/Max.

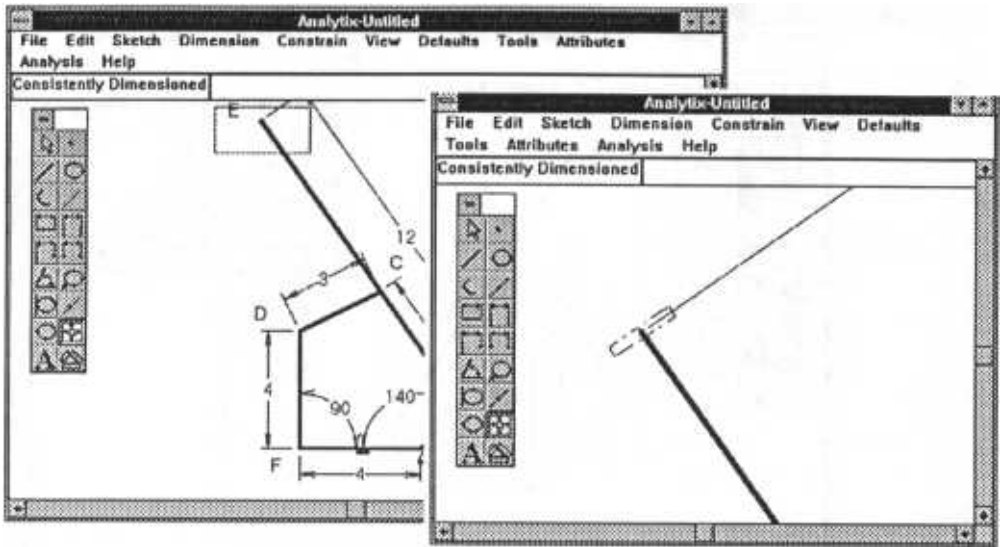

Tolerance Stack-up

With the tolerances in place, the perpendicular distance between line DF and point E will also contain a tolerance that can be derived from the tolerances of the various entities in the geometry. Analytix can measure the distance and its tolerance. It can also compute the tolerance percentage contributions each of the entities made to the total distance tolerance.

To measure the perpendicular distance between line DF and point E:



- *Select line DF*
- *Press and hold down shift key*
- *Select point E*
- *Select Attributes / Measure*

The measurement appears in a popup window showing the distance and tolerance values.

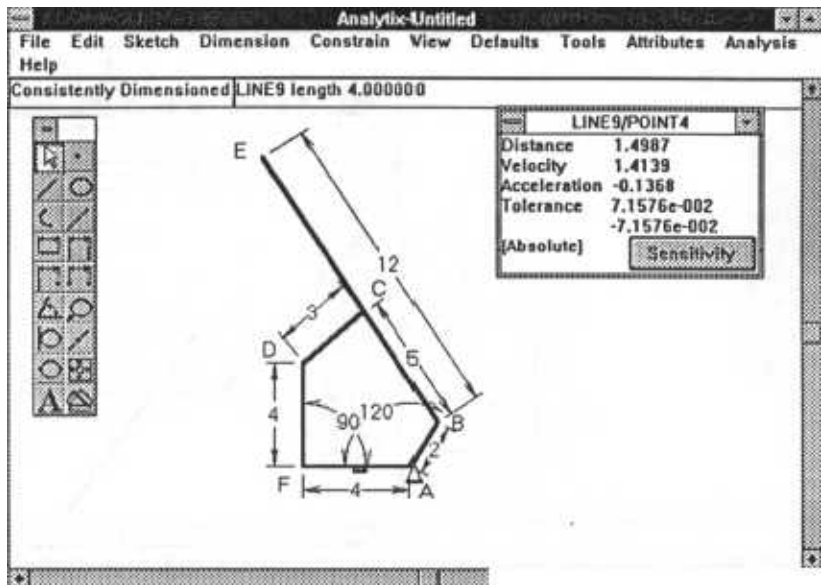

To see the percentage contributions made by other entities in the geometry to the distance tolerance, click on the Sensitivity button. A Sensitivity window appears displaying the percentage contributions to the distance tolerance by the entities which are identified by their dimensions.

If you want to know which entity is referenced, click on the dimension name in the Sensitivity window and the dimension of that entity in the drawing will be highlighted in red.

With the Sensitivity window open, you can change individual tolerances by double clicking on the dimension and adjusting the input tolerances. See the sensitivity percentages change instantly.

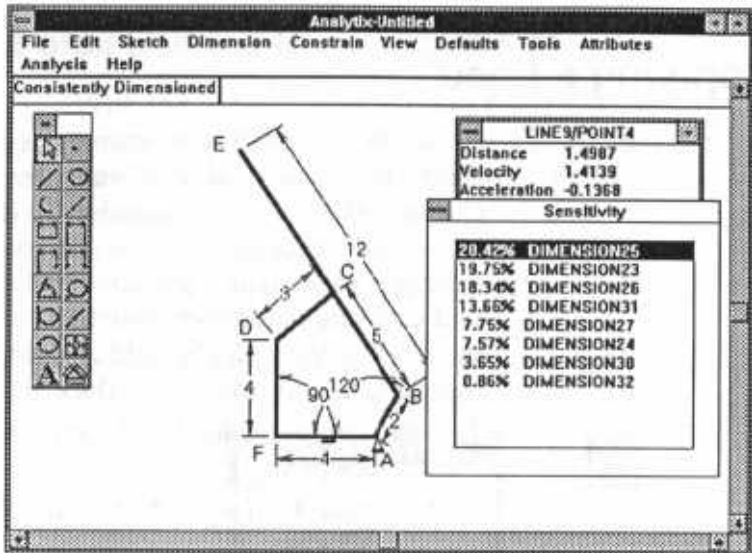

Statistical Tolerance

The above tolerance analysis is calculated based on absolute bounds for the input tolerances. Analytix will also calculate tolerances on a statistical basis assuming a Normal Distribution. See discussion under **Defaults/ Statistical Tolerance in the reference manual** for a detailed explanation.

Applying a Load

In addition to the dynamic analysis capabilities, Analytix is also capable of analyzing static characteristics of a mechanism. To demonstrate the static analysis capability, we will continue with our example; we will apply a upward load at point E and examine the force exerted to line CD at point C by line BE. We will also add a spring to the mechanism and investigate the effect on point C.

To add an upward load of 10 at point E:

- *Select point E*
- *Select Analysis /Add Load to display the Load dialog box*
- *Enter "10" to the y field as in the following figure*
- *Click on Ok*

Analytix displays an upward arrow labeled with "10" pointing at point E to indicate the load.

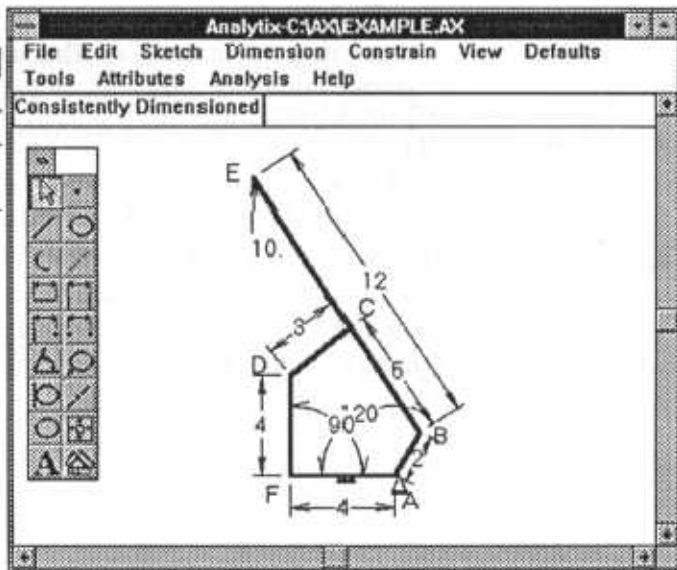
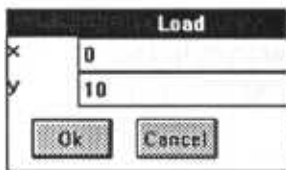

Examine the Force Exerted to a Subsystem

With the upward load at point E, we wish to examine the force exerted to line CD at point C by line BE. The procedure to examine the force is as follows:



- *Select line CD*
- *Select Analysis/ Force on Pin*
- *Click on point C*

Analytix displays the force applied to line DC at point C in the following information window.

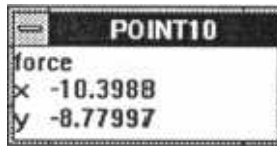

POINT10	
force	
x	-10.3988
y	-8.77997

Note that because the mechanism is in equilibrium, the net force at point C is zero. That is, if we examine the force exerted to line BE at point C by line CD, we will see a force that is the same in magnitude but opposite in direction to the previous force. To examine this force, we do the following:



- *Select line BE*
- *Select Analysis/ Force on Pin*
- *Click on point C*

Analytix displays the force on point C by line DC in the following figure. Note magnitude and direction of the x and y component force are exactly as we have predicted.

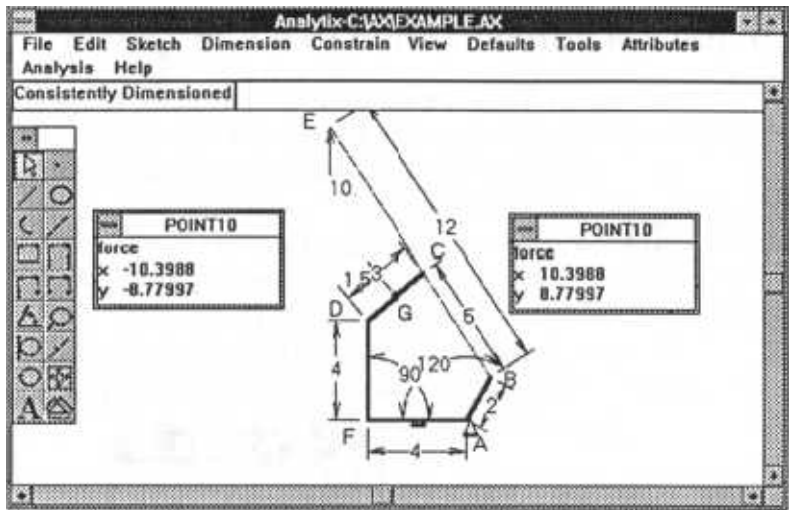

Adding a Spring

We will now add a spring that connects point F and the center of line DC and examine the effect that this spring has on point C.

Before adding the spring, we will add a point that is located at the center of line DC through the following steps:



- *Select the Sketch Point icon*
- *Move the cursor to the approximate center of line DC and click the left mouse button to place the point*
- *Select the Dimension Point to Point icon*
- *Click on point D*
- *Click on the point lying on line DC and hold down the button*
- *Drag the dimension line to the desired location*
- *Release the left button to display the dimension dialog box on top of the Dimension Status Box*
- *Enter 1.5 to the dialog box*
- *Click on Y*

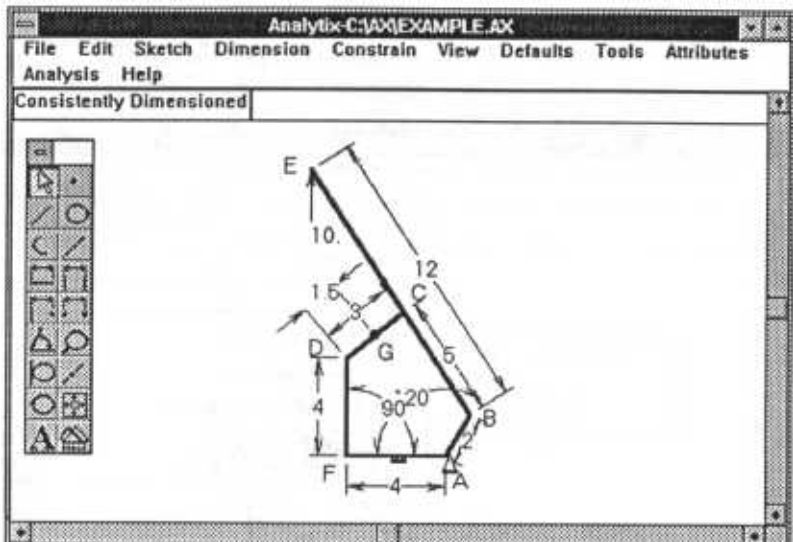

Dimensioning the point places the point at the center of line DC. Annotate this point as point G using the annotation procedure discussed previously.

With point G added, we will add a spring that connects point F and G as follows:



- *Select point F*
- *Hold down the Shift key and select point G*
- *Select the Analysis /Add Actuator menu item to pop up the actuator dialog box*
- *Enter "4" in the Unextended length field*
- *Click on the Spring box to select it*
- *Enter the spring constant "10" in the Stiffness field*
- *Click on the Black Box box to deselect it*

Click on the Ok button

Actuator

Unextended length

Spring

Stiffness

Damper

Constant

Black Box

Tension Only

Compression Only

Tension and Compression

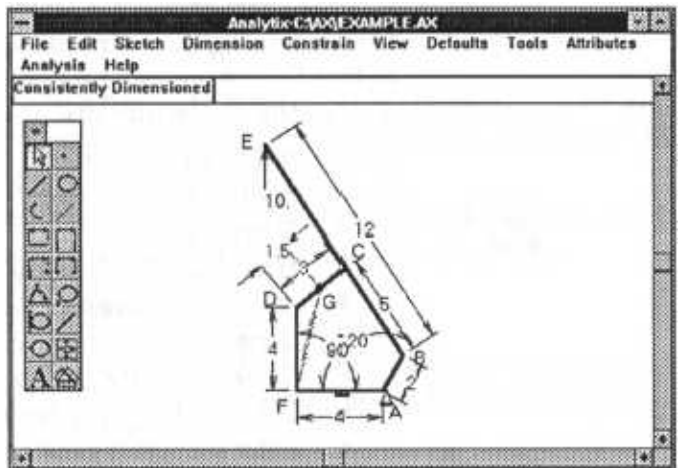

Examine Force



With the added spring, we will examine the effect that it has on the force exerted by line BE on point C.

- *Select line CD*
- *Select Analysis /Force on Pin*
- *Select point C*

Analytix displays the force on a pop-up window, as shown below. Compare the above force with the forces calculated previously.

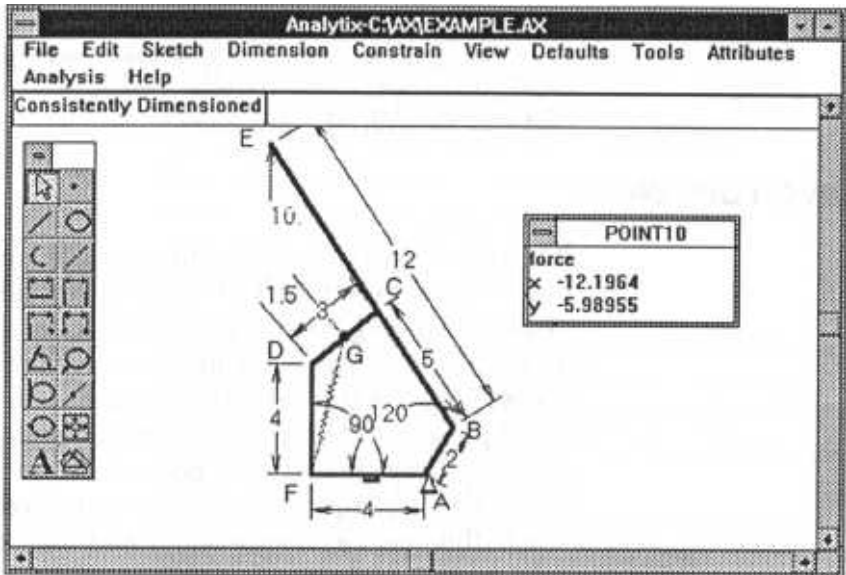

Finishing Up

After design and analysis of the mechanism, there are a few details you need to know: saving your work, incorporating Analytix results in your report, and exiting from the program.

Save Your Work

It is a good idea to periodically save the work to a file. You can select the File / Save menu item which displays a dialog box for you to select the directory in which to save your file and to enter the file name. We will use the current directory and enter "example.ax". When you click the Ok button, all the work we have created until now will be saved in a file named "example.ax" in the current directory. The pathname, i.e., the directory and file name appear on the title bar.

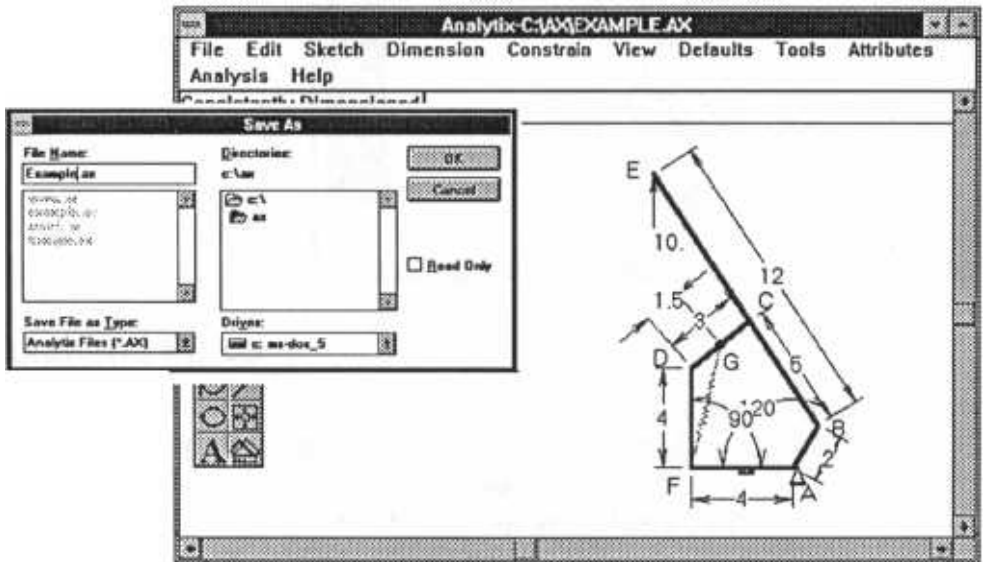

Document Your Work

Everything that is displayed in the Analytix workspace (drawing, annotation, graphs, tables, information windows, etc.) can be transferred to your documents such as office memos, technical papers, or manuals via Windows' Clipboard and the Analytix Edit / Snap function. This section illustrates the steps required to bring your work from Analytix into another document.

Add Annotation and Graph

We first add to our example an annotation of the torque in angle FAB and a graph. We insert the annotation as previously described, but use the "Q" character to incorporate an active value, in this case a function, into the text. Enter

"Torque=@react(dimension32)@" in the annotation dialog box. For further detail see Sketch / Annotation in your reference manual. We also add another annotation text, "New Camera Drive" at the bottom of the drawing.

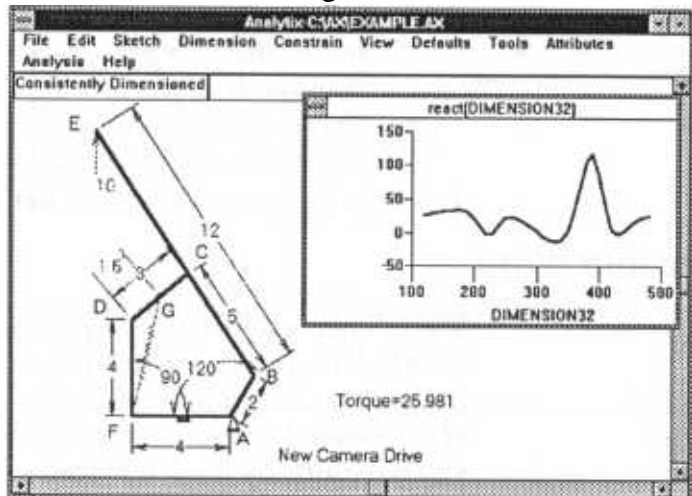

Next, we add a graph of resultant torque on angle FAB to the workspace using the procedure previously described.

Copying the Screen Shot to the Clipboard is a Snap

We will copy the screen shot of the Analytix Window to Windows' Clipboard using the Snap function:

- *Select the Edit / Snap menu item*

The Snap offers you several choices -

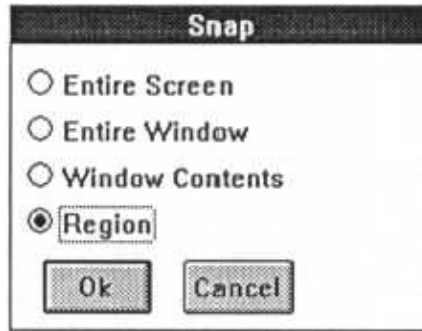

- *Click the Region selection*
- *Click on Ok*
- *Position the cursor at the upper left corner of the desired area to be selected and hold down the left mouse button*
- *Drag the selection box so that it encloses the area to be selected and release the mouse button*

You have just copied a screen shot to the Clipboard.

Paste into Word

The following figure shows a memo written in Word. This memo contains normal text and the drawing pasted from Clipboard. Pasting the content of Clipboard is performed as follows (assuming that you have already invoked Word and typed the text):

- *Move the typing cursor to the position where you want the drawing to appear*
- *Select Edit/ Paste from Word's menu selections to paste the drawing from the Clipboard*

To: John

From: Dave

Date: 23 April 1993

Subj: The new camera drive

John,

The following figure shows the resultant torque of angle FAB in the new camera drive. The annotation shows the torque at 120 degrees while the graph describes the torque change from 120 to 480 degrees.

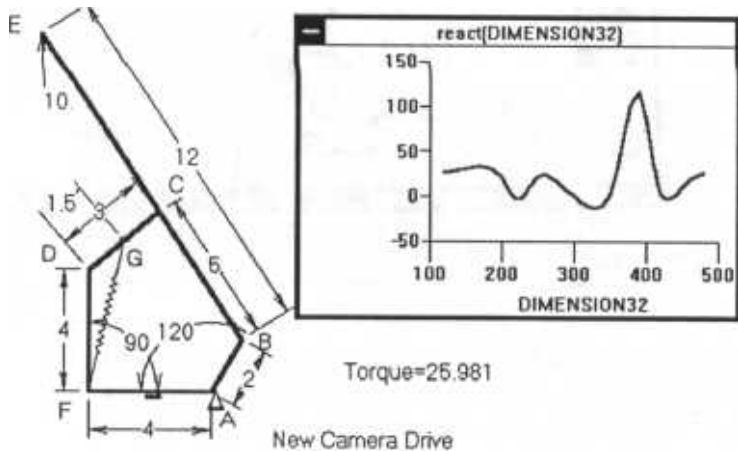

Please let me know if you have any questions.

Dave

Exit Analytix



To exit Analytix, select the Close menu item from the System menu, the horizontal bar at the upper left corner of the Analytix window. Alternatively you can double click on the System menu bar.

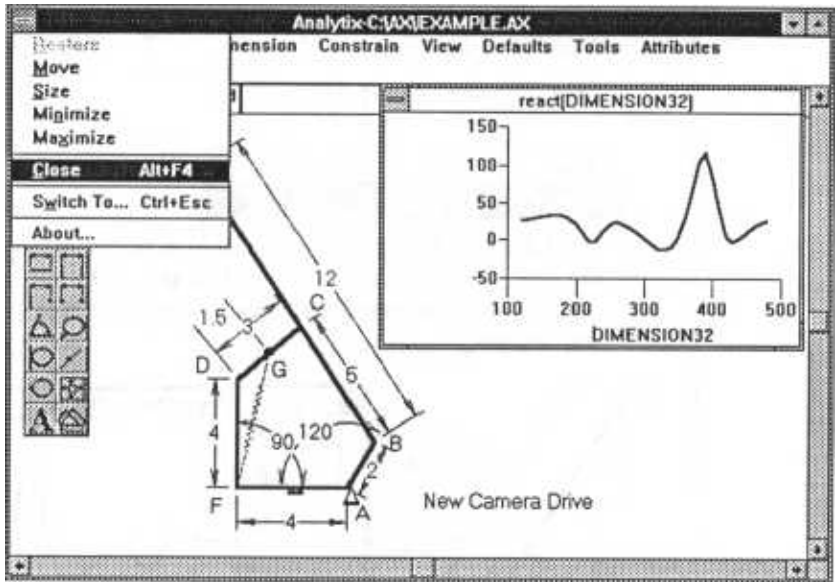

Inconsistencies & Redundancies

As dimensioning a drawing is the key to the power of Analytix we have included some additional notes on this topic.

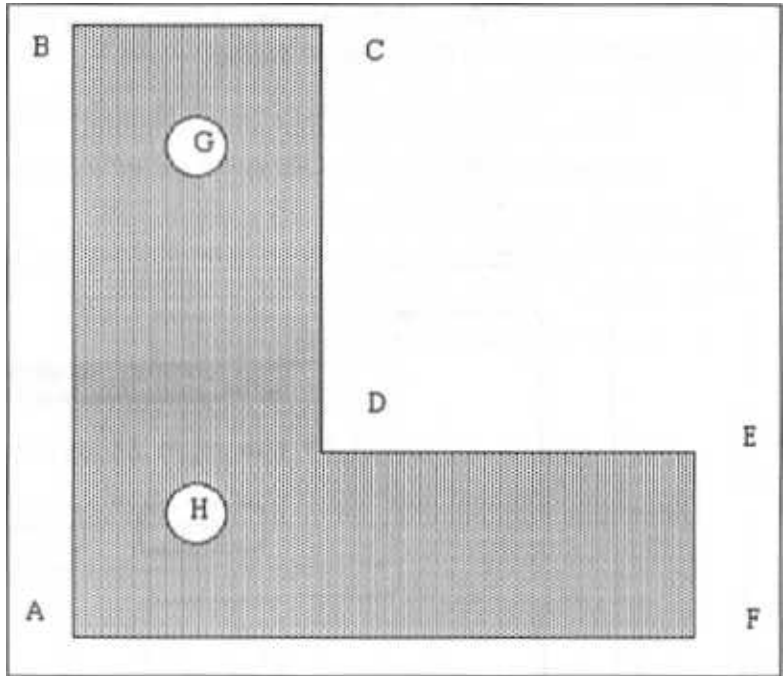

In this section, we will see what happens when we attempt to add dimensions which are redundant (too many dimensions), or inconsistent (dimensions do not "add up").

We will use as an example the design of an L shaped block with two circular holes.

First, we ignore the holes and sketch the L shaped block.

We will use Parallel Distance to dimension the block.



Pick Parallel Distance icon on the tool bar.

Click on line AB; position the cursor over line EF, depress the left mouse button and drag down to the bottom of the drawing.

A parallel distance dimension will appear.

When the dimension symbol is correctly positioned, release the mouse button.

Enter the distance between these lines: 10.

Now dimension the parallel distance between lines AB and CD: 4.

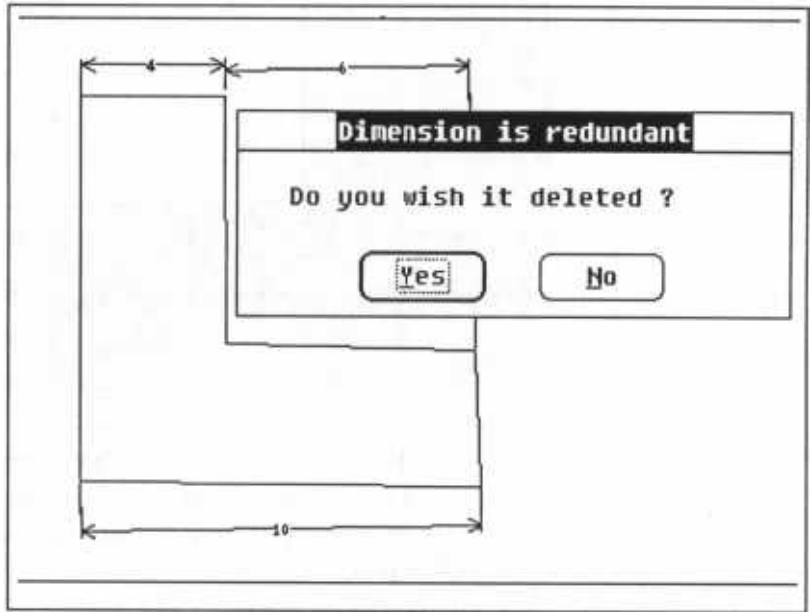

Redundant Dimensions

Now dimension the parallel distance 6 between lines CD and EF.

You will see a message box warning you that this dimension is redundant, and giving you the option of deleting it.

The dimension is redundant because the distance between CD and EF is already defined as a result of the distance between lines AB and EF and the distance between lines AB and CD.

If we do not delete this redundant dimension, we must delete some other dimension before we can obtain a consistently dimensioned figure.

Click on Yes to delete the redundant dimension.

We complete the dimensioning of the L shape by adding parallel distance dimension of 10 between

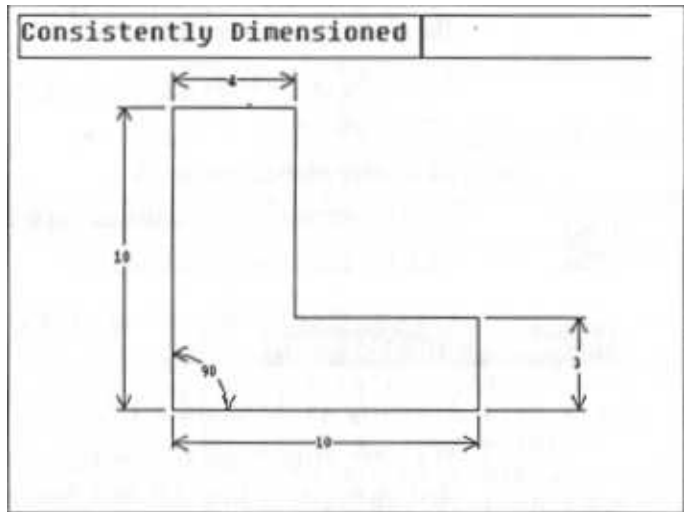

lines AF and BC and 3 between lines AF and DE and a 90 degree angle between AB and AF.



To add the angle, select the Dimension Angle icon.

Click on line AB and then on line AF.

An angle dimension symbol will appear between the lines.

Enter 90 in the dimension entry box (by default, Analytix measures angles in degrees).

The drawing should now be consistently dimensioned and Analytix should give us a scale drawing.

Inconsistent dimension

We will now add the circular holes G and H to the drawing and in the process illustrate what Analytix does when dimensions are inconsistent.



Pick the Sketch Circle icon.

Position the cursor in the approximate location of the center of circle G, depress the left mouse button and drag the circumference of the circle .

When the circle looks about the right size, release the mouse button.

Similarly sketch circle H.

We dimension the radius of each circle to be 1.



Pick the Dimension Radius icon.

Click on the circumference of circle G. Enter the radius of 1 in the dimension entry box.

Similarly set the radius of circle H to be 1.

We now dimension the center of circle G to lie distance 2 from line AB and distance 2 from line BC.



Pick the Dimension Line to Point icon.

Click on line AB.

Position the cursor over the circumference of circle G, depress the left mouse button, and drag the dimension symbol.

When the dimension symbol is appropriately positioned, release the mouse button.

Enter the dimension value -2 - into the dimension entry box.

Similarly dimension the center of circle G to lie distance 2 from line BC.

Now dimension the center of circle H to lie distance 2 from line AF and distance 5 from the center of circle G.

To specify the distance from the center of G:

- Pick the Dimension Point to Point icon.
- Click on the circumference of circle G.
- Position the mouse over the circumference of circle H.
- Depress the left mouse button and drag the dimension symbol.
- Release the mouse button and enter the dimension value in the dimension entry box.

